

Detached Garage

Private Garages



Based on the 2020 Minnesota State Building Code

MR = Minnesota State Building Code extracted from 2020 Minnesota Rules

IRC = International Residential Code

NEC = National Electrical Code

Detached Residential Garage

Permit Requirements:

Building permits are required for construction of all new garages whether they are attached to the house or built as a detached structure. The Minnesota State Building Code differentiates between attached and detached garages; there are some differences in the requirements. The construction of detached residential garages shall meet the requirements of the 2020 Minnesota State Building Code which adopts and amends the 2012 International Residential Code.

Zoning Requirements:

Detached garages must also meet the land use and setback requirements of the Rochester Land Development Manual and Zoning Ordinances. Zoning questions should be directed to the Community Development Department at 507-328-2600.

Permit Fees: <https://www.rochestermn.gov/government/departments/building-safety/construction-residential>

An estimate of the permit costs are based on the material and labor valuation—which is the either the amount charged by a contractor for the work or for DIY work, double the materials cost. An example would be to take the materials times two for DIY estimates. This keeps the permit costs consistent whether done as DIY or by hired contractor.

Plan Review & Inspections:

A Plan Review is performed by the Plans Examiner in order to identify potential problems prior to construction. If more information is needed during Review, the Plans Examiner will email a correction letter and a copy of the plans to the applicant. Once the corrections are completed, they should be emailed back to the Examiner who requested them. Inspections will be performed during construction to ensure Code compliance and that the materials used are installed correctly. The Plan Review and Inspections are not designed to be a guarantee of the work; rather they are done to provide a reasonable degree of review and observation so the project will be successful, safe and long lasting.

Submittals for permit:

The following information is necessary for the Building Safety Department to do a proper Plan Review and help the project to go as smoothly as possible.

Note: Sample plans provided in this handout are intended as a guide only.

- ◆ Apply online with attached pdf files at: <https://aca.rochestermn.gov/CitizenAccess/>
- ◆ A copy of the site plan. The site plan should indicate the proposed garage location including distances from other structures/property lines, dimensions of garage, and lot dimensions as well as a note indicating any grade changes (see floor plan). A copy of the existing site plan may be obtained from the Building Safety Department if one is on file.
- ◆ Identify electrical utilities on site plan. The NEC has specific requirements with location to clearance over driveways or roofs, depending on the pitch of the roof. Also, direct buried conductors must be in a raceway when located beneath a building.

- ◆ The construction plans which should include floor plans showing proposed design and materials and a section drawing. For engineered structures and garages exceeding 1,000 square feet, additional requirements may apply. Plans shall be drawn to scale and indicate the following information:
 - A floor plan including the following: (see sample plan)
 1. Proposed size of garage.
 2. Location and size of window and door openings.
 3. Size of headers above garage doors (see header table).
 4. Size, spacing and direction of roof framing.
 - A section drawing indicating the following: (see sample plan)
 1. Height of wall from slab to top plate.
 2. Height of wall studs from bottom plate to top plate.
 3. Size and depth of footings.
 4. Floor design and material.
 5. Wall and roof construction.
 6. Type (grade & species) of lumber to be used.
 7. Slab and foundation detail including reinforcing, if any.
 8. Braced wall panel details and nailing patterns.

Building Code Requirements:

- ◆ A slab-on-grade may be used for the foundation support of detached garages on all soils except peat and muck. Sod, root and other organic materials must be removed. The perimeter of the slab must be thickened to a minimum vertical dimension of 12" at the edge with a minimum 6" grade separation along the exterior from wood framing and siding. The bottom of the thickened edge must be at least 12" wide and then may be sloped upward at a 45 degree angle to meet the bottom of the slab. The minimum slab thickness must be 3-1/2". The minimum concrete strength is required to be 3500 pounds per square inch (see sample plan). MR 1303.1600 Subp. 2 & IRC R403.1.4
- ◆ Foundation plates or sills must be bolted to the foundation with not less than 1/2" diameter steel bolts embedded at least 7" into the concrete and spaced not more than 6'-0" apart. Other approved sill plate anchors may be used. There must be a minimum of two bolts or anchors per piece with one bolt or anchor located within 12" of each end of each piece. IRC R403.1.6
- ◆ Sills and sleepers on a concrete slab or masonry that are in direct contact with the ground must be separated from such slab by an impervious moisture barrier or be an approved species and grade of lumber, pressure treated or decay-resistant heartwood of redwood, black locust, or cedars. Sills shall have a width not less than that of the wall studs. IRC R317
- ◆ Studs must be placed with their wide dimension perpendicular to the wall, and not less than three studs must be installed at each corner of an exterior wall. Typical wall framing is 2"x4" studs spaced at 16" on center. Alternate framing with a stud spacing of 24" on center will require additional construction methods for top plates and wall sheathing. IRC R602

- ◆ Wood stud walls shall be capped with double or triple top plates depending on wall stud spacing and installed to provide overlapping at corners and intersections with bearing partitions. End joints in top plates shall be offset at least 24". IRC R602.3.2
- ◆ Braced wall lines with braced wall panels a minimum of 48 inches wide shall be provided no more than 12.5 feet from end of braced wall line and spaced not more than 25 feet apart. The required width of braced wall panels may be reduced depending on wall sheathing material or alternate framing methods. IRC R602.10
- ◆ Approved wall sheathing and siding must be installed according to the manufacturer's specifications. IRC R703
- ◆ Roof sheathing and roof coverings must be installed according to manufacturer's specifications. IRC R903
- ◆ If permanent heat is provided then additional Code requirements such as insulation/vapor barrier in walls and ceilings, vapor retarders and insulation below floor slab and ice protection at roof eaves may be required.
- ◆ Exterior walls less than 5 feet from the property line shall have not less than a one-hour fire resistive rating with exposure from both sides. Projections shall not extend more than 12" into areas where openings are prohibited. Openings are not permitted in an exterior wall that is less than 3'-0" from the property line. From 3'-0" to 5'-0" the wall may contain openings not to exceed 25% of the wall area. Detached garages within 2 feet of a lot line are permitted to have eave projections not exceeding 4 inches. IRC R302.1(1) MN Amendment
- ◆ Roof trusses shall be designed and constructed to support a minimum snow load (live load) of 35 pounds per square foot. The bottom chord must be designed for a minimum 10 pounds live load per square foot if not used for storage and 20 pounds live load per square foot if used for limited storage. Engineered certified truss drawings shall be on site at the time of the framing inspection. Trusses designed for storage or useable space shall be indicated on the floor plans at the time of building permit application and the design loads shall be indicated on the truss drawings. If hand framing is used, please submit drawings and details of the proposed framing. IRC R802, IRC Tables R301.2(1) MN Amendment and R301.5

Required Inspections:

Every effort is made to perform all inspections the next business day following the request.

Inspections may be scheduled on line at: www.rochestermn.gov/CitizenAccess.

- **Or call 507-328-2600 and please have your permit number available when you call. Inspectors' work schedules fill up fast at certain times of the year, so if you can call more than a day in advance you may avoid any potential delays in the progress of your project.**

1. Footing/Concrete slab

- To be scheduled after all form work is set up, all required reinforcement is in place and supported **PRIOR TO THE POURING OF CONCRETE.**

2. Framing

- To be scheduled after all framing, blocking, and bracing are in place, rough electrical (if any) is approved, and roof covering materials are installed and prior to closing the construction (which would make it inaccessible for inspection). Wall construction for braced wall panels and fire resistive rated walls needs to be inspected prior to the installation of weather resistive barriers and siding materials. Engineered certified truss drawings shall be on site at the time of inspection. (The framing and final inspection can be completed at the same time if all parts of the framing will be visible and accessible at the final inspection.)

3. Final

- To be scheduled upon completion of the garage and finish grade.

4. Other Inspections

- In addition to the three inspections above, the inspector may make or require other inspections to ensure compliance with the provisions of the Code or to assist you with questions or concerns during the construction process.

General Notes:

- ◆ The plans & inspection card shall be available on the job site for all inspections and until the final inspection has been performed and approved.
- ◆ **All hired contractors must be licensed by the State of Minnesota, or have a Certificate of Exemption from the State of Minnesota.**
- ◆ **Call Gopher One at least 2 full days before you dig at 1-800-252-1166 or send an email to www.gopherstateonecall.org**

SAMPLE SITE PLAN

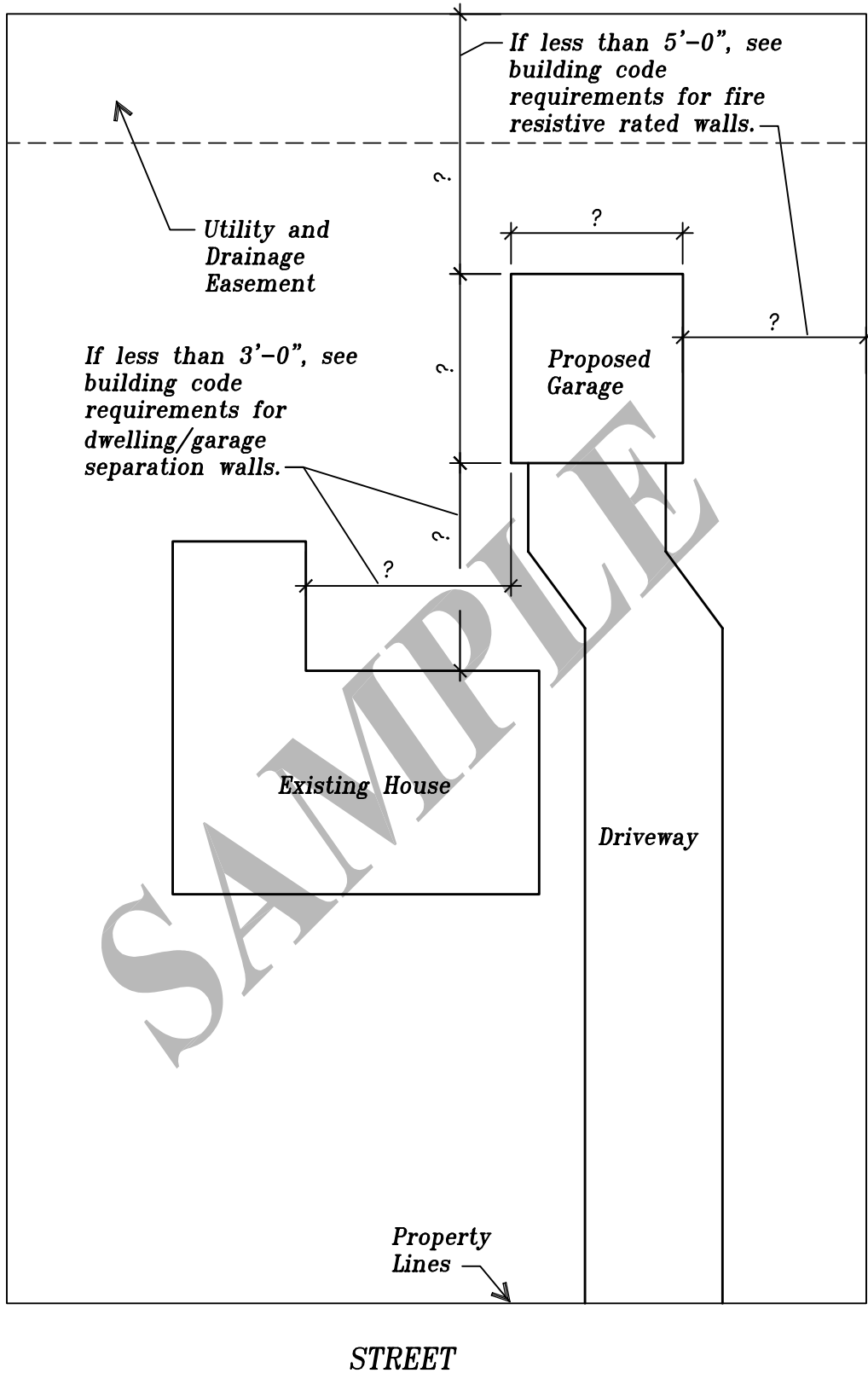

Note:

Show any additional structures that exist on the property (i.e. Pool, Shed etc.)

Indicate grade elevation difference from front of garage (+ or - X'-X")

An approved fire resistive rated wall is required when less than 5'-0" to the property line

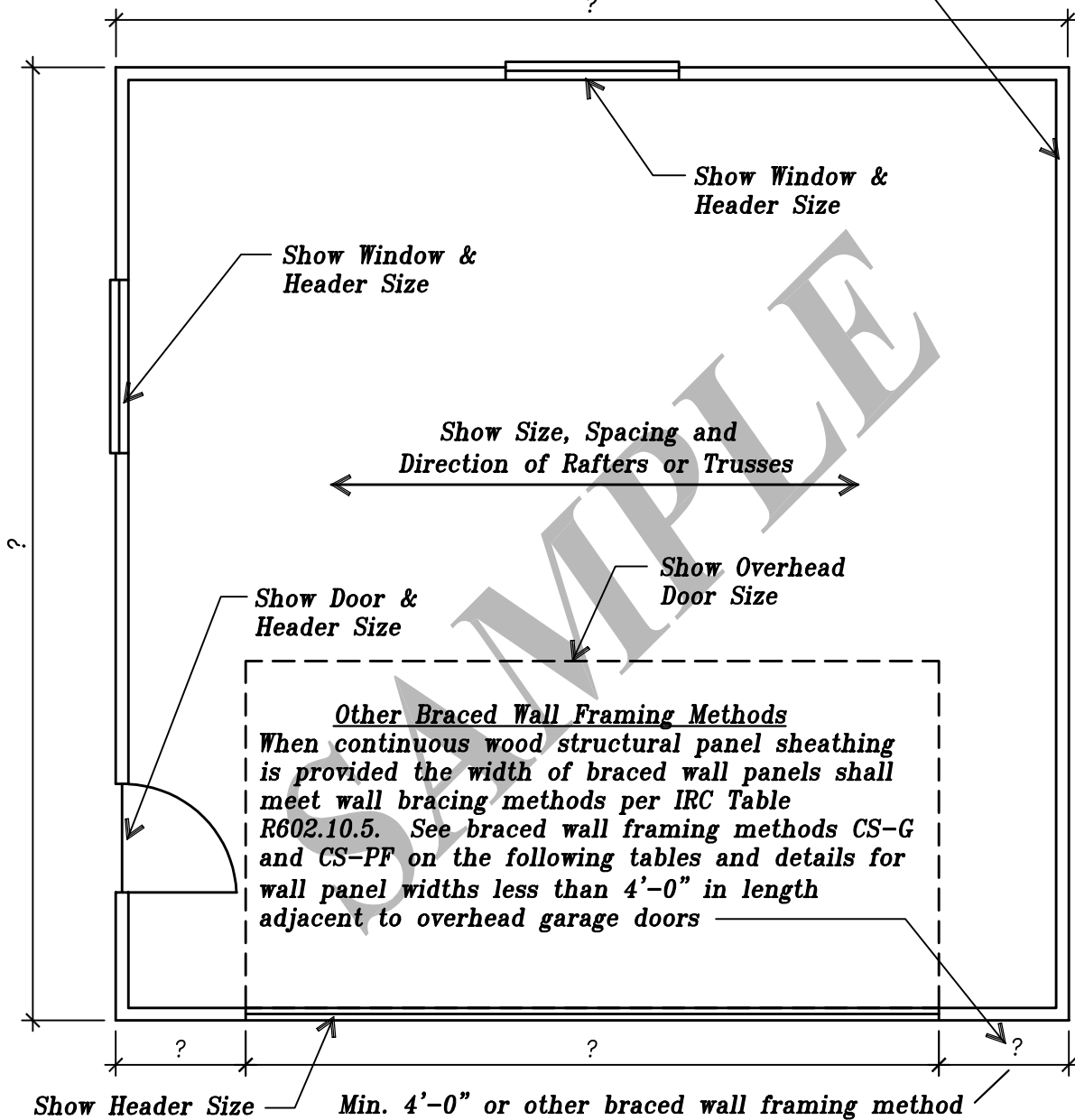

FLOOR PLAN

CS-G Method a,b

(Continuously Sheathed Wood Structural Panel Adjacent to Garage Door Opening)

Based on IRC Tables R602.10.4 and R602.10.5

	Wall Height				
	8-foot wall	9-foot wall	10-foot wall	11-foot wall	12-foot wall
Minimum Length(inches) of Braced Wall Panel ^c	24	27	30	33	36

- a. At garage door openings when supporting gable end wall or roof load only. May only be used on one wall of the garage. Roof covering dead load may not exceed 3 psf.
- b. A header sufficient to support roof and ceiling loads based on IRC Table R502.5.(1). A full clear height opening shall not be permitted adjacent to the CS-G braced wall panel.
- c. Linear interpolation shall be permitted.

CS-PF Method a,b
(Continuously Sheathed Portal Frame)

Based on IRC Tables R602.10.4, R602.10.5 and Section/Figure R602.10.6.4

	Wall Height				
	8-foot wall	9-foot wall	10-foot wall	11-foot wall	12-foot wall
Minimum Length(inches) of Braced Wall Panel ^c	16	18	20	22 ^d	24 ^d

- a. CS-PF braced wall panel shall be constructed in accordance with Figure R602.10.6.4. See CS-PF detail for construction requirements.
- b. The number of continuously sheathed portal framed panels in a single braced wall line shall not exceed four.
- c. Linear interpolation shall be permitted.
- d. Maximum opening height for CS-PF is 10 feet in accordance with Figure R602.10.6.4, but wall height may be increased to 12 feet with pony wall. See CS-PF detail below.

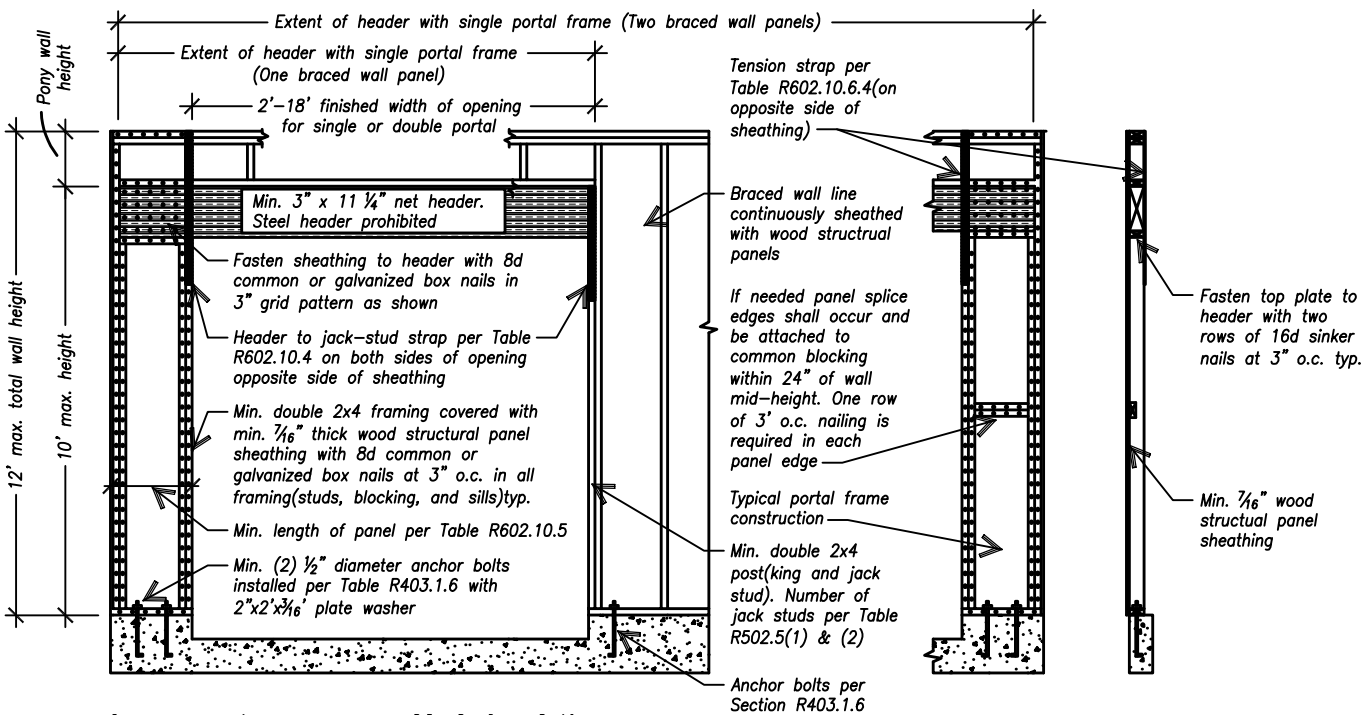

Over concrete or masonry block foundation

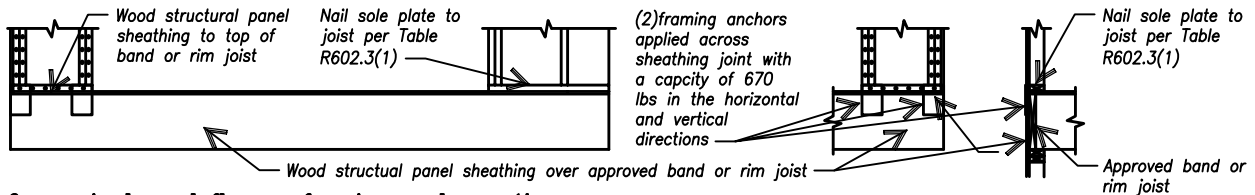

Over raised wood floor - framing anchor option

(When portal sheathing does not lap over band or rim joist)

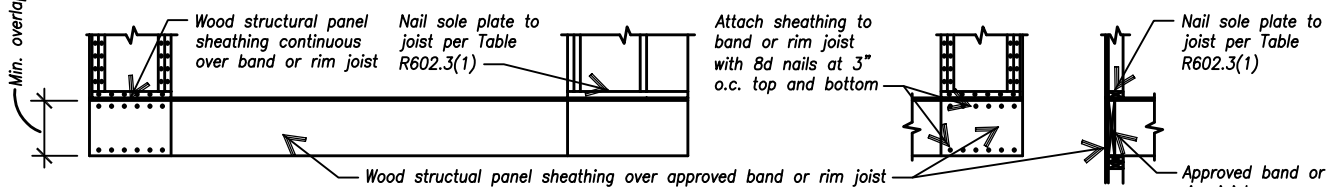

Over raised wood floor - overlap option

(When portal sheathing does laps over band or rim joist)

Front Elevation

Section

CS-PF Detail

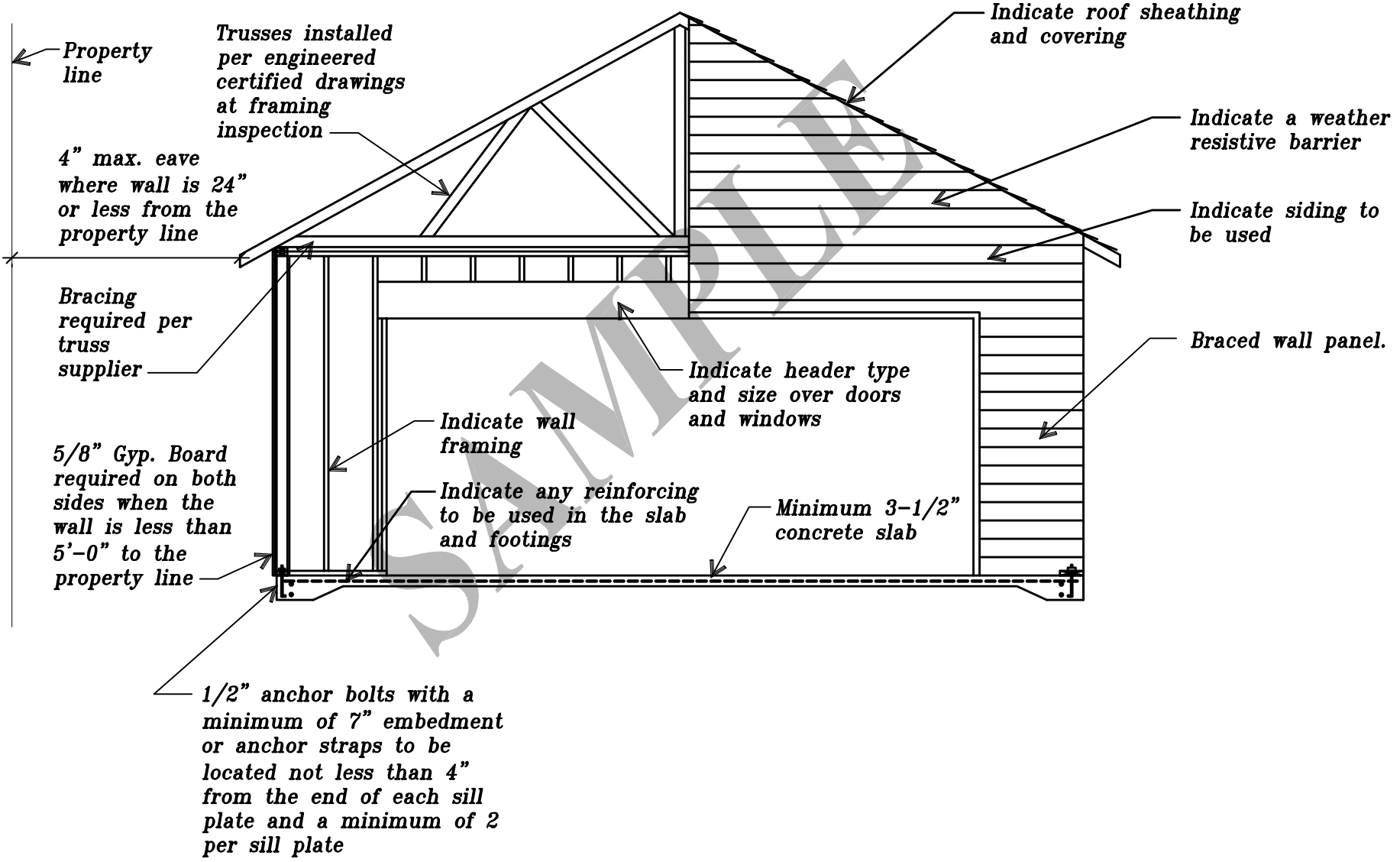

SECTION \ ELEVATION

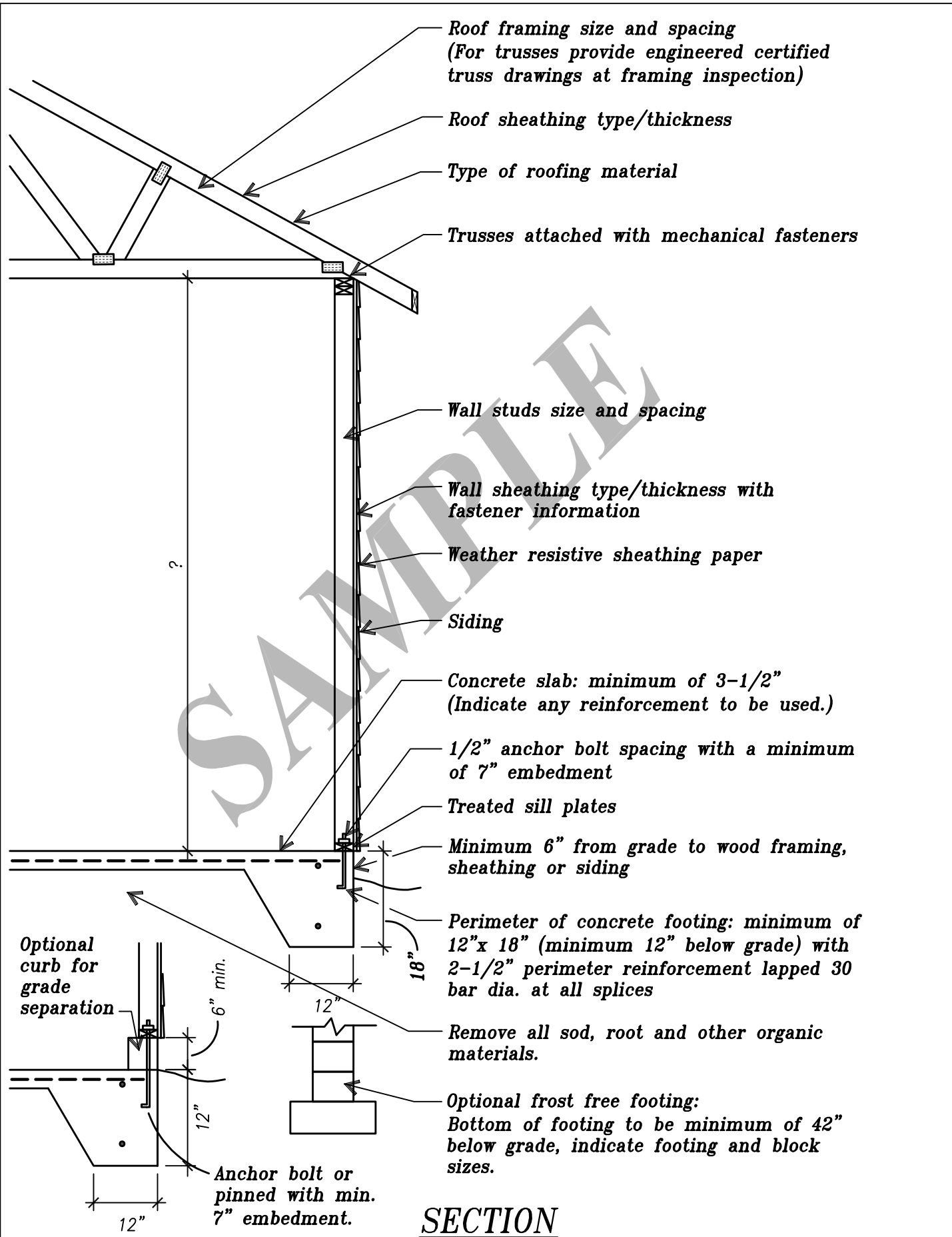

GARAGE DOOR HEADER TABLE

for load bearing walls of detached garages

(Design load = 35 PSF SNOW LOAD+10 PSF BOTTOM CHORD LIVE LOAD = 45 PSF TL, (no attic storage)

(Design load = 35 PSF SNOW LOAD+20 PSF BOTTOM CHORD LIVE LOAD = 55 PSF TL, (limited attic storage)

Eave to ridge distance (includes 2'-0" overhang) See example below

Garage Door Width (ft)	10'-0"	12'-0"	14'-0"	16'-0"	18'-0"
8'-0"	(2) 2x12 *	(3) 2x12 * (1) 9-1/2 EL	(3) 2x12 * (1) 9-1/2 EL	(3) 2x12 * (1) 9-1/2 EL	(2) 9-1/2 EL * (1) 11-7/8 EL
9'-0"	(3) 2x12 * (1) 9-1/2 EL	(3) 2x12 * (1) 9-1/2 EL	(2) 9-1/2 EL * (1) 11-7/8 EL	(2) 9-1/2 EL * (1) 11-7/8 EL	(2) 9-1/2 EL * (1) 11-7/8 EL
10'-0"	(3) 2x12 * (1) 9-1/2 EL	(2) 9-1/2 EL * (1) 11-7/8 EL	(2) 9-1/2 EL * (1) 11-7/8 EL	(2) 9-1/2 EL * (1) 11-7/8 EL	(2) 9-1/2 EL ** (2) 11-7/8 EL
12'-0"	(2) 9-1/2 EL * (1) 11-7/8 EL	(2) 9-1/2 EL * (2) 11-7/8 EL	(3) 9-1/2 EL ** (2) 11-7/8 EL	(3) 9-1/2 EL ** (2) 11-7/8 EL	(2) 11-7/8 EL ** W8x24
16'-0"	(2) 11-7/8 EL ** W6x25 W8x18	(2) 11-7/8 EL ** (2) 14 EL W8x18	(3) 11-7/8 EL ** (2) 14 EL W8x21	(3) 11-7/8 EL ** (2) 14 EL W8x24	(3) 11-7/8 EL ** W8x24

NOTES

Header span and header sizes for openings in non-bearing walls. (with 2'-0" overhang)

12'-0" span = (2) 2x8, 16'-0" span = (2) 2x12

Table is based on #2 Hem-Fir (Fb = 850 psi)

KEY

* Depicts a need for 2 cripples under each end of header.

** Depicts a need for 3 cripples under each end of header.

EL = Engineered lumber. (Min. Fb = 2600 psi, 1.9E)

WXxXX = Steel beam size. (min. Fy = 36 ksi)

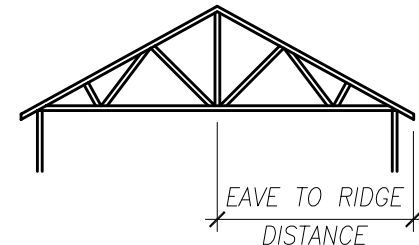

Special Conditions / Recommendations

STEM WALL ON DETACHED SLAB ON GRADE FLOORS

for maximum grade of 2'-0" above slab

- ① Perimeter: (2) 1/2" reinforcing
Slab floor: two way grid of 3/8" reinforcing 2'-0" o.c.
- ② 1/2" vertical reinforcing 2'-0" o.c. hooked into slab and grouted block.
4 course (max) 8" (min) block with 3 courses retaining soil over 12" x 8" perimeter footing.
- ③ Treated bottom plate minimum anchorage: 1/2" anchor embedded 7" and not more than 6'-0" o.c. or 1'-0" from ends. and there shall be a minimum of 2 anchors per wall piece.
- ④ 4" perimeter drain tile to daylight. 1'-0" minimum pearock fill.

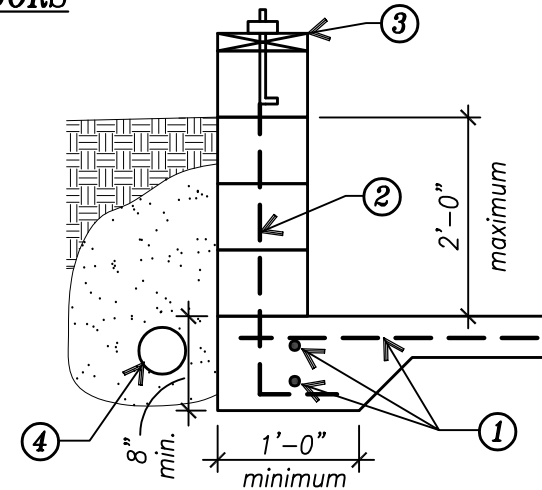

DROP WALL WITH SLAB ON GRADE

for maximum grade of 2'-6" below top of slab

- ① Maximum of 2'-6" above grade with a minimum of 6" embedment. (see detail)
- ② Perimeter: (3) 1/2" reinforcing horizontal.
Drop walls: 12" thick. 1/2" reinforcing drops at 2'-0" o.c. tied to each horizontal reinforcing. Continuous corners and overlap reinforcing 1'-8" in slab.
- ③ Slab floor (minimum 3 1/2"): two-way grid of 3/8" reinforcing 2'-0" o.c., Minimum 3500 pounds per square inch air entrained concrete.
- ④ Weep holes: 1/2" screened tubes at 6'-0" o.c. cast in back wall, 6" above grade.
- ⑤ Fill material: 6" lifts of compacted gravel or sand.

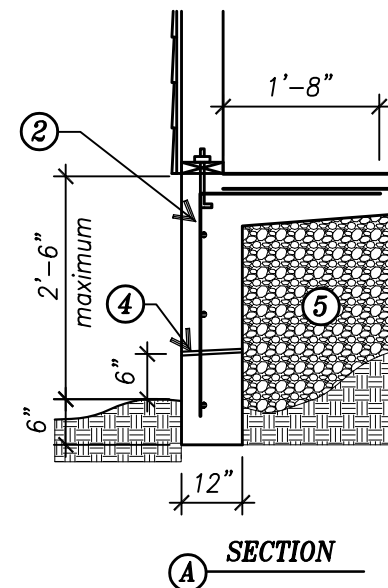
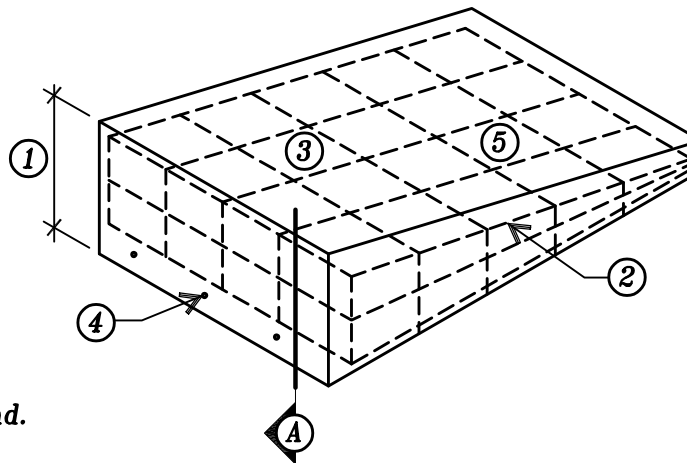

NOTE: Remove all sod and organic materials prior to concrete pour.